

Clarke®

METALWORKER



BENCH GRINDER

MODEL NO: CBG150

PART NO: 6500757

OPERATING & MAINTENANCE INSTRUCTIONS



ORIGINAL INSTRUCTIONS

GC11/23

INTRODUCTION

Thank you for purchasing this CLARKE Bench Grinder.

Before attempting to use this product, please read this manual thoroughly and follow the instructions carefully. In doing so you will ensure the safety of yourself and that of others around you, and you can look forward to your purchase giving you long and satisfactory service.

GUARANTEE

This product is guaranteed against faulty manufacture for a period of 12 months from the date of purchase. Please keep your receipt which will be required as proof of purchase.

This guarantee is invalid if the product is found to have been abused or tampered with in any way, or not used for the purpose for which it was intended.

Faulty goods should be returned to their place of purchase, no product can be returned to us without prior permission.

This guarantee does not effect your statutory rights.

SPECIFICATIONS

Weight	5.35 kg
Grinding Stone Dimensions	150 dia x 16 mm thick (12.7mm bore)
Grinding Stone grade	36 Coarse/60 Medium (max 4450 rpm)
Rated Voltage / Frequency	230 V / 50 Hz
Rated Input Wattage	150 W
No Load Speed	2980 rpm
Ingress protection rating	IP30
Duty cycle classification	S1 = 105W - S6 40% =150W
Product dimensions	290 x 230 x 200mm (guards & tool rest fitted)

GENERAL SAFETY RULES



CAUTION: FAILURE TO FOLLOW THESE PRECAUTIONS COULD RESULT IN PERSONAL INJURY, AND/OR DAMAGE TO PROPERTY.

WORK ENVIRONMENT

1. Keep the work area clean, tidy and well lit. Cluttered and dark areas invite accidents
2. DO NOT operate power tools in explosive atmospheres, such as in the presence of flammable liquids, gases or dust. Power tools create sparks which may ignite the dust or fumes.
3. Keep children and bystanders away while operating a power tool. Distractions can cause you to lose control.

PERSONAL SAFETY

1. Stay alert, watch what you are doing and use common sense when operating a power tool. DO NOT use a power tool while you are tired or under the influence of drugs, alcohol or medication. A moment of inattention while operating power tools may result in personal injury.
2. Avoid accidental starting. Ensure the switch is in the off position before plugging in. Plugging in power tools that have the switch on invites accidents.
3. DO NOT overreach. Keep proper footing and balance at all times. This enables better control of the power tool in unexpected situations.
4. Dress properly. DO NOT wear loose clothing or jewellery. Keep your hair, clothing and gloves away from moving parts. Loose clothes, jewellery or long hair can be caught in moving parts.
5. Eye protection manufactured to the current European safety standards should be worn when operating grinding equipment. Eye protectors must provide protection from flying particles from the front and the side.

GENERAL USE AND CARE OF POWER TOOLS

1. ALWAYS check for any damage or condition that could affect the grinder's operation. Any damaged part should be properly repaired.
2. NEVER use the grinder if it is defective or operating abnormally.
3. NEVER abuse the mains cable. NEVER yank the cable to disconnect it from the socket. Keep the cable away from sharp edges/hot surfaces.

4. NEVER carry out any alterations or modifications to this product.
5. NEVER wipe the machine clean with solvents. Wipe plastic parts with a soft cloth, slightly dampened with soapy water.
6. NEVER attempt any repairs yourself. If you have a problem with this product contact your local CLARKE dealer.
7. DO NOT use the tool for any purpose than that described in this manual.
8. ALWAYS maintain the tool with care. Keep it clean for the best and safest performance.
9. DO NOT force the power tool. Use the correct power tool for your application. The correct power tool will do the job better and safer at the rate which it was designed.
10. DO NOT use the power tool if the switch does not turn it on and off. Any power tool that cannot be controlled with the switch is dangerous and must be repaired.
11. Store idle tools out of the reach of children and do not allow persons unfamiliar with the power tool or these instructions to operate the power tool. Power tools are dangerous in the hands of untrained users.
12. Maintain power tools. Check for misalignment or binding of moving parts, breakage of parts and any other condition that may affect the power tools operation. If damaged, have the power tool repaired before use. Many accidents are caused by poorly maintained power tools.
13. Use the power tool and accessories in accordance with these instructions and in the manner intended for the particular type of power tool, taking into account the working conditions and the work to be performed. Use of the power tool for operations different from intended could result in a hazardous situation.

ELECTRICAL SAFETY

1. Power tool plugs must match the outlet. NEVER modify the plug in any way. DO NOT use adapter plugs with earthed (grounded) power tools. Correct plugs and matching outlets will reduce the risk of electric shock.
2. DO NOT abuse the cable. NEVER use it for carrying, pulling or unplugging the power tool. Keep the cable away from heat, oil, sharp edges or moving parts. Damaged or entangled cables increase the risk of electric shock.
3. DO NOT expose power tools to rain or wet conditions. Water entering a power tool will increase the risk of electric shock. If operating the power tool in a damp location is unavoidable, use a residual current device (RCD) protected supply.

4. When operating a power tool outdoors, use an extension cable suitable for outdoor use. Use of a cable suitable for outdoor use reduces the risk of electric shock.

GRINDING STONE SAFETY

1. Check the speed of the grindstone before fitting to your grinder. NEVER use a stone with a rpm speed less than the rpm speed of your grinder. See specification on page 2.
2. The outside diameter and thickness of your accessories must be within the capacity rating of the power tool. The correct size accessories can be correctly guarded and controlled.
3. NEVER use a stone that is chipped, cracked or damaged. Fragments from a broken or damaged grinding stone can cause serious injury. Make sure that defective stones are destroyed and not used.
4. Bonded abrasive products are breakable and shall therefore be handled with utmost care. The use of damaged or improperly mounted or used abrasive products is dangerous and can cause serious injuries.
5. ALWAYS refer to the label for specified usage and observe the safety information. DO NOT use for purposes other than specified.
6. ALWAYS use the correct stone for it's intended task. Using the incorrect stone can cause serious injury.
7. Allow the stone and tool to do the work. NEVER force the workpiece against the stone as this could cause kickback and/or shatter the stone causing serious injury.
8. DO NOT use separate reducing bushes or adapters to adapt large hole abrasive wheels. DO NOT force a stone onto a machine or alter the size of the arbor hole.
9. NEVER use a damaged grinding stone. Inspect the stone before each use for chips, cracks or excess wear. If the tool or accessory is dropped, inspect for damage or install a new accessory. After fitting the accessory, position yourself away from the plane of the rotating accessory and run the tool at full speed. Damaged stones may break apart during this test.
10. Abrasive products shall be handled and transported with care. Abrasive products shall be stored in such a manner that they are not subjected to mechanical damage and harmful environmental influences.

BENCH GRINDER SAFETY WARNINGS

1. Hold a hand tool or blade being sharpened firmly to prevent loss of control.
2. NEVER install a abrasive flap wheel or sanding disc on this grinder.
3. ALWAYS replace a cracked grinding wheel immediately.

4. NEVER use damaged or incorrect grindstones. The stone and retaining fixtures were specially designed for your grinder, for optimum performance and safety of operation. Inspect the condition of the grinding stone before use and do not use if any damage is found.
5. ALWAYS use the tool rests to steady the workpiece, the torque of the spinning grinding wheel may pull the workpiece from your hands.
6. ALWAYS check for damaged parts. Before further use any part that is damaged should be carefully checked to determine if it would operate properly and perform its intended function. Check for misalignment or binding of moving parts, breakage of parts and any other condition that may affect the tool's operation. A part that is damaged should be properly repaired or replaced at an authorised service center. Following this rule will reduce the risk of electric shock, fire or serious injury.

NOTE: Bench grinders used in industrial environments may be subject to the requirements of The Provision and Use of Work Equipment regulations 1992 (particularly regarding the training requirement of The Abrasive Wheels Regulations 1970), or other legislation. If in doubt seek advice.

Please keep these instructions in a safe place for future reference.

SAFETY SYMBOLS

The meanings of the markings and symbols on the product are shown below

	Read this manual before use and keep in a safe place for future reference		Wear eye protection when using this tool.
	Wear ear protection when grinding.		Wear dust mask.

ELECTRICAL CONNECTIONS



WARNING! READ THESE ELECTRICAL SAFETY INSTRUCTIONS FULLY BEFORE CONNECTING THE MACHINE TO THE MAINS SUPPLY.

This machine is provided with a standard 13 amp, 230 volt (50Hz), BS 1363 plug, for connection to a standard, domestic electrical supply. Should the plug need changing, make sure that a plug of identical specification is used.



WARNING! THE WIRES IN THE POWER CABLE OF THIS PRODUCT ARE COLOURED IN ACCORDANCE WITH THE FOLLOWING CODE: BLUE = NEUTRAL BROWN = LIVE YELLOW AND GREEN = EARTH

If the colours of the wires in the power cable do not agree with the markings on the plug:

- Connect the **blue** wire to the terminal which is marked **N**.
- Connect the **brown** wire to the terminal which is marked **L**.
- Connect the **yellow and green** wire to the terminal which is marked **E** or .

Plug must be BS1363/A approved.

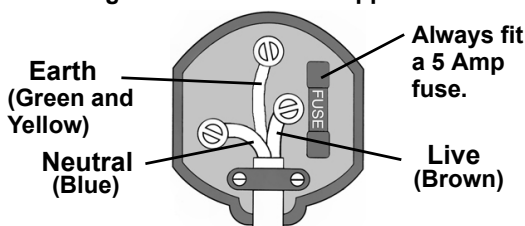

Ensure that the outer sheath of the cable is firmly held by the clamp

We strongly recommend that this machine is connected to the mains supply through a Residual Current Device (RCD)

If you are not sure, consult a qualified electrician. **DO NOT** try to do any repairs.

CABLE EXTENSIONS

Always use an approved cable extension suitable for the power rating of this machine. The conductor size should also be at least the same size as that on the machine, or larger and should have an earth conductor.

OVERVIEW

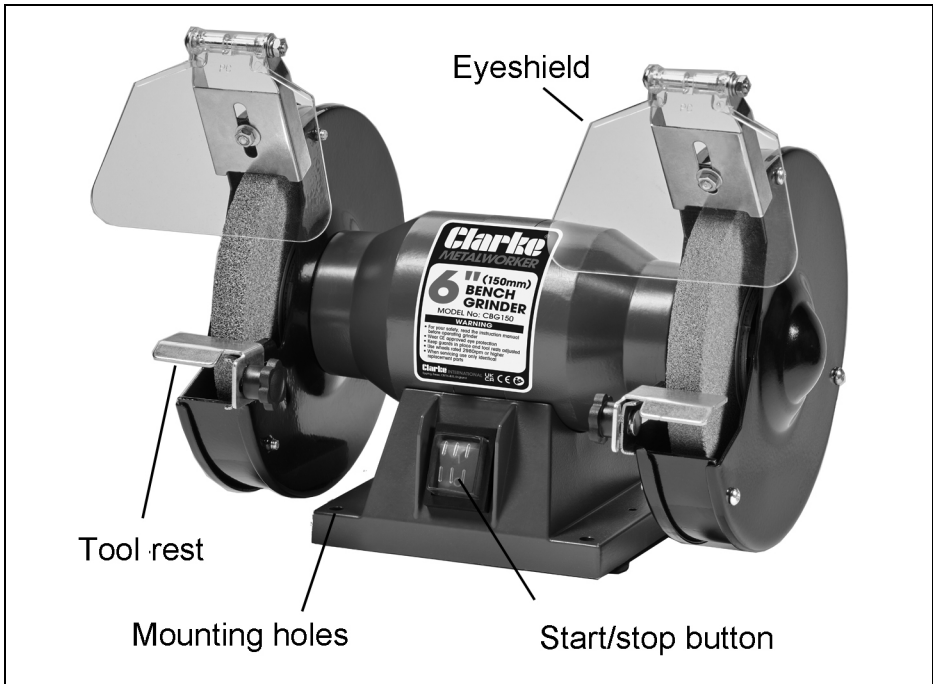

The following items should be supplied with the bench grinder. If any items are missing or damaged, please contact the CLARKE dealer where you purchased the product.

- Two eye shield assemblies (each with nut, bolt, spring washer & 2 x flat washers)
- Two tool rests (each with knob, screw, spring washer & flat washer)
- Hand knobs and fixings for the above
- Coarse wheel (fitted)
- Medium wheel (fitted)

ASSEMBLY

1. Fix the tool rests with the locking knobs short coach bolts and washers provided, as shown in Fig.1.
 - The tool rests are adjustable and should be positioned 2.5mm (1/8") from the grinding wheels. Ensure that the tool rest is firmly fixed and horizontal.
 - As the wheel wears down with use, it will be necessary to re-adjust the toolrest brackets in order to maintain a gap between the rest and the wheel.
2. Assemble the eye shields on to the brackets using the nuts, screws and washers supplied, as shown in Fig.2.
 - The angle for the eye shields can be adjusted to suit the operator.

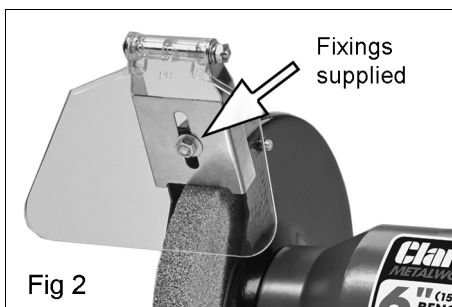
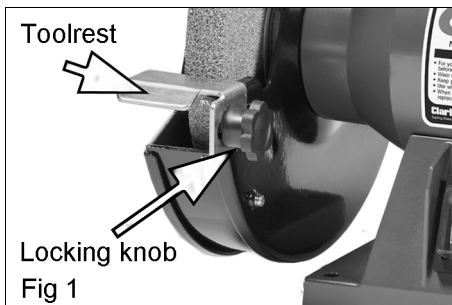

IMPORTANT: We recommend that your bench grinder is secured to your workbench before operation, using the pre-drilled holes in the base. DO NOT overtighten the mounting bolts as this could damage the base. Position the machine in good light.

USING YOUR BENCH GRINDER



WARNING: FRAGMENTS FROM A BROKEN/DETACHED GRINDING WHEEL CAN CAUSE INJURY.

WARNING: ENSURE THAT THE WORKING POSITION ADOPTED DOES NOT CAUSE OPERATOR FATIGUE WHICH MAY LEAD TO LOSS OF CONTROL OF THE TOOL BEING GROUND.

WARNING: THE WHEEL WILL CONTINUE TO ROTATE BRIEFLY AFTER THE OFF SWITCH HAS BEEN PRESSED.

GENERAL USE

1. To start/stop the grinder, press the ON/OFF switch and start work.
2. Press the tool blade evenly onto the grinding stone and move the tool sideways across the stone. Make sure that at least half the width of the tool cutting edge comes into contact with the grinding stone at any time to avoid damage to the stone.
3. Allow the stone to do the work. DO NOT apply excessive downward pressure on the tool when grinding.

EYESHIELD ADJUSTMENT

The transparent eye shields allow the user to see the work clearly and to work precisely. The eye shields can be adjusted up and down as required.

The brackets should be adjusted so that they are as close as possible to the grinding wheel without impairing the wheels rotation.

IMPORTANT: Even though the eye shields are fitted, you should nevertheless wear safety goggles when operating a bench grinder.

TOOLREST ADJUSTMENT

The appropriate adjustment of the tool rests provides the operator with a correct working angle and a firm and efficient base for working. Adjustments can be made by loosening the mounting screws and moving the tool rest to within 1.6mm (1/16") from the wheel.

Due to the wear on the grinding wheel, it will be necessary to adjust the tool rests from time to time. Always re-tighten the mounting thumbscrews once adjustment is complete.

MAINTENANCE

GENERAL MAINTENANCE

Make sure that all components are tight and secure. Always have any damaged or worn parts repaired or replaced by qualified service personnel. DO NOT attempt to repair the grinder unless you are qualified to do so.

The drive motor and bearings are sealed units and require no regular maintenance. Should you require assistance, contact your local CLARKE service agent.

The stone will wear down with use and may well go out of true. Use a dressing wheel or stone grader to correct the trueness and to remove worn, glazed grains from the stone.

The stone will have a finite life expectancy, dependant upon the nature of the work being done. Periodically, make a note of the wheel diameter and replace your (150mm) dia wheel if it reduces to an little as (130mm) in diameter.

INSTALLING A NEW GRINDING STONE



CAUTION: NEVER RE-START THE GRINDER WITHOUT THE GUARDS INSTALLED.

To renew or change the grinding wheels, proceed as follows

1. Switch off and un-plug from power supply. Remove the outer covers, left or right, by removing the three cover retaining screws.
2. Hold the grinding wheel firmly and remove the nut and flange from the shaft, noting that the **left hand wheel nut has a left hand thread**.
3. Take off the used wheel and replace with the new one, ensuring:
 - the paper label/blotters are in place either side of the wheel.
 - that there is a good balanced rotation of the grinding wheel
 - you do not overtighten the wheel nut.
4. Re-fit covers, left or right, by using the three cover retaining screws.
5. Re-adjust the tool rest and spark arrester brackets if required.
6. Switch the machine on and allow it to rotate freely for at least one minute.

Replacement grinding stones are available from your CLARKE dealer.

DRESSING A NEW STONE

New grinding stones are frequently not true or in time can become grooved, glazed (built-up), out of round or otherwise mis-shapen. To correct these defects, a grinding stone dresser is available from your CLARKE dealer.

- ET125 Grinding Wheel Dresser - Part No:1700225
 - Replacement Dresser Wheel - Part No:1700230
 - ET154 ½ Carat Diamond Tip Wheel Dresser - part No:1700329
1. If the grinding stone is new, allow it to spin for a minute with no load. Check that it is spinning straight and true. If not, it will require dressing before use.
 2. Stand to the side of the stone and hold the dresser handle firmly. Place the dresser on the tool support so that its wheels can move freely (i.e. the exposed part of the wheel should be facing up). Run the stone and apply the dresser to the surface of the stone.

CLEANING & STORAGE

Clean the exterior the machine if required using a mild detergent or mild solvent. Never immerse the machine in water. To reduce any fire hazard, keep any cooling vents in the grinder free of debris.

If not bolted to a workbench, store the grinder in a clean, dry location, out of reach of children.

ENVIRONMENTAL PROTECTION



Do not dispose of this product with general household waste. All tools, accessories and packaging should be sorted, taken to a recycling centre and disposed of according to the laws governing Waste Electrical and Electronic Equipment.

Through the purchase of this product, the customer is taking on the obligation to deal with the WEEE in accordance with the WEEE regulations in relation to the treatment, recycling & recovery and environmentally sound disposal of the WEEE.

In effect, this means that this product must not be disposed of with general household waste. It must be disposed of according to the laws governing Waste Electrical and Electronic Equipment (WEEE) at a recognised disposal facility.

DECLARATIONS OF CONFORMITY



Clarke[®]
INTERNATIONAL
Fitzwilliam Hall, Fitzwilliam Place, Dublin 2

DECLARATION OF CONFORMITY

This is an important document and should be retained.

We hereby declare that this product(s) complies with the following legislation:

2014/30/EU Electromagnetic Compatibility Directive
2006/42/EC Machinery Directive
2011/65/EU The Restriction of Use of Certain Substances in Electrical and Electronic Equipment (RoHS) Directive

The following standards have been applied to the product(s):

EN IEC 55014-1:2021, EN IEC 55014-2:2021, EN IEC 61000-3-2:2019/A1:2021,
EN IEC 61000-3-3:2013/A2:2021, EN 62841-1:2015, EN 62841-3-4:2016/A1:2020,
EN 62321-1:2013, EN 62321-2:2014, EN 62321-3-1:2014, EN 62321-4:2014, EN 62321-5:2014,
EN 62321-6:2015, EN 62321-7-1:2015, EN 62321-7-2:2017, EN 62321-8:2017.

The technical documentation required to demonstrate that the product(s) meet(s) the requirement(s) of the aforementioned legislation has been compiled and is available for inspection by the relevant enforcement authorities.

The CE mark was first applied in: 2023

Product Description: 150W Bench Grinder
Model Number(s): CBG150
Serial/Batch Number: Refer to product/packaging label
Date of Issue: 28/09/2023

Signed:

J.A. Clarke
Director

CBG150 CE Clarke DOC 092923

Page 1 of 1



Clarke[®]
INTERNATIONAL
Hemnal Street, Epping, Essex, CM16 4LG

DECLARATION OF CONFORMITY

This is an important document and should be retained.

We hereby declare that this product(s) complies with the following legislation:

Electromagnetic Compatibility Regulations 2016
Supply of Machinery (Safety) Regulations 2008
The Restriction of the Use of Certain Hazardous Substances in Electrical & Electronic Equipment Regulation 2012

The following standards have been applied to the product(s):

EN IEC 55014-1:2021, EN IEC 55014-2:2021, EN IEC 61000-3-2:2019/A1:2021,
EN IEC 61000-3-3:2013/A2:2021, EN 62841-1:2015, EN 62841-3-4:2016/A1:2020,
EN 62321-1:2013, EN 62321-2:2014, EN 62321-3-1:2014, EN 62321-4:2014, EN 62321-5:2014,
EN 62321-6:2015, EN 62321-7-1:2015, EN 62321-7-2:2017, EN 62321-8:2017.

The technical documentation required to demonstrate that the product(s) meet(s) the requirement(s) of the aforementioned legislation has been compiled and is available for inspection by the relevant enforcement authorities.

The CE mark was first applied in: 2023

Product Description: 150W Bench Grinder
Model Number(s): CBG150
Serial/Batch Number: Refer to product/packaging label
Date of Issue: 29/09/2023

Signed:

J.A. Clarke
Director

CBG150 UKCA Clarke DOC 092923

Page 1 of 1

COMPONENT PARTS

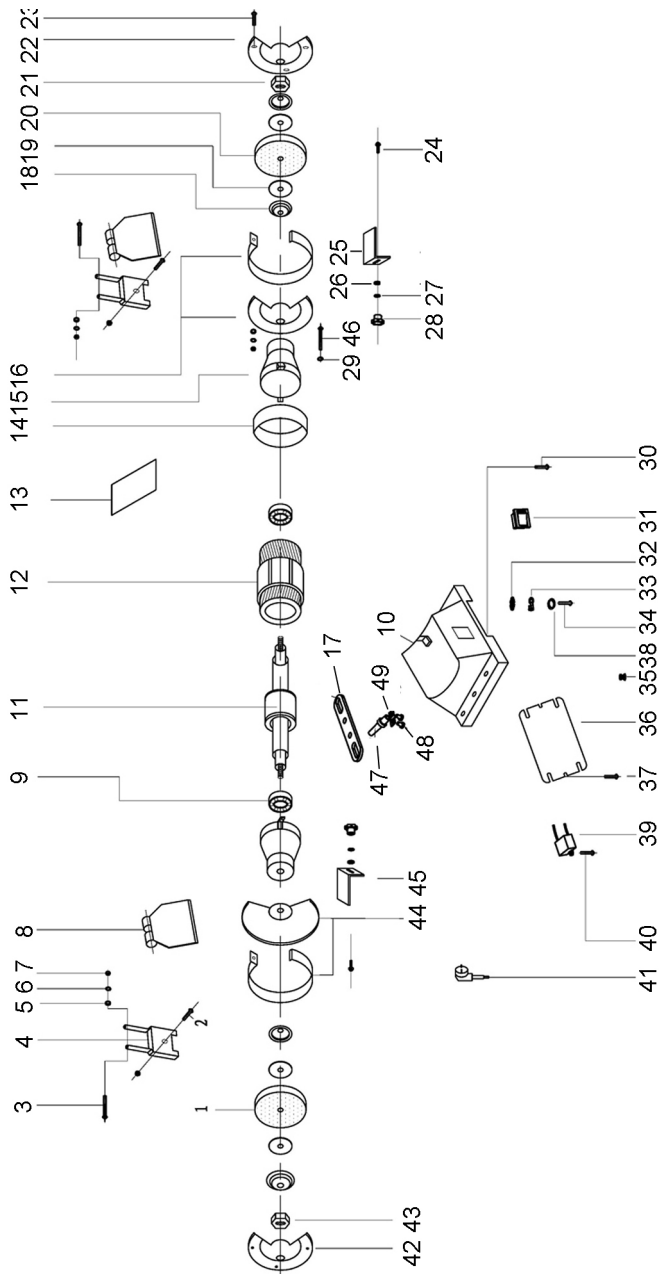

COMPONENT PARTS

No	Description
1	Grinding wheel
2	Bolt/nut washer
3	Screw
4	Eyeshield bracket
5	Washer
6	Spring washer
7	Nut
8	Eyeshield
9	Bearing
10	Base
11	Motor rotor
12	Motor stator
13	Nameplate
14	Closing ring
15	Cover
16	Right inner guard
17	Pressing plate
18	Wheel flange
19	Wheel branding
20	Grinding wheel
21	Nut
22	Right outer guard
23	Screw
24	Coachbolt
25	Right tool rest

No	Description
26	Tooth washer
27	Washer
28	Hand knob
29	Spring washer
30	Bolt/nut washer
31	Switch
32	Tooth washer
33	Ground terminal
34	Screw
35	Rubber foot
36	Base plate
37	Screw
38	Spring washer
39	Capacitor
40	Screw
41	Power cable & plug
42	Left inner guard
43	Nut
44	Left outer guard
45	Left tool rest
46	Screw
47	Cable adaptor
48	Screw
49	Cable clip

Replacement 150mm grinding wheels are available:

- **Coarse; part no 6501070**
- **Medium: - part no 6501054**
- **Fine; - part no 6501053**

A SELECTION FROM THE VAST RANGE OF

Clarke®

QUALITY PRODUCTS



AIR COMPRESSORS

From DIY to industrial, Plus air tools, spray guns and accessories.

GENERATORS

Prime duty or emergency standby for business, home and leisure.

POWER WASHERS

Hot and cold, electric and engine driven - we have what you need

WELDERS

Mig, Arc, Tig and Spot.
From DIY to auto/industrial.

METALWORKING

Drills, grinders and saws for DIY and professional use.

WOODWORKING

Saws, sanders, lathes, mortisers and dust extraction.

HYDRAULICS

Cranes, body repair kits, transmission jacks for all types of workshop use.

WATER PUMPS

Submersible, electric and engine driven for DIY, agriculture and industry.

POWER TOOLS

Angle grinders, cordless drill sets, saws and sanders.

STARTERS/CHARGERS

All sizes for car and commercial use.



PARTS & SERVICE: 0208 988 7400

Parts Enquiries
Parts@clarkeinternational.com

Servicing & Technical Enquiries
Service@clarkeinternational.com

SALES: UK 01992 565333 or Export 00 44 (0)1992 565335

Clarke INTERNATIONAL Hemnall Street, Epping, Essex CM16 4LG
www.clarkeinternational.com